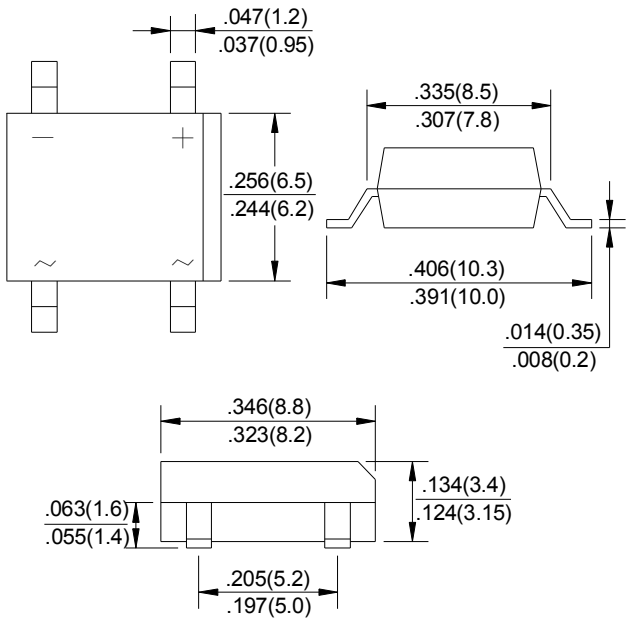

**VI. Bridge Rectifier**

**1.5A SMD Glass Passivated Bridge Rectifier  
DB151GS~DB157GS**

**(Package: DBS)**

<p><b><u>FEATURES</u></b></p> <ul style="list-style-type: none"> <li>• Rating to 1000V PRV</li> <li>• Ideal for printed circuit board</li> <li>• Low forward voltage drop, high current capability</li> <li>• Reliable low cost construction utilizing molded plastic technique results in inexpensive product</li> <li>• The plastic material has Underwriters Laboratory Flammability Classification 94V-0</li> </ul> <p><b><u>MECHANICAL DATA</u></b></p> <ul style="list-style-type: none"> <li>• Polarity : As marked on body</li> <li>• Mounting position : Any</li> <li>• Weight : 0.02 ounces, 0.38 grams</li> </ul>	 <p style="text-align: center;">Case: DBS Dimensions in inches and (millimeters)</p>
--	---

**Ratings & Electrical Characteristics**

Ratings at 25 ambient temperature unless otherwise specified.

Single phase half-wave 60 Hz, resistive or inductive load, for capacitive load current derate by 20%.

Characteristic	Symbol	DB	DB	DB	DB	DB	DB	DB	Units
		151GS	152GS	153GS	154GS	155GS	156GS	157GS	
Maximum recurrent peak reverse voltage	$V_{RRM}$	50	100	200	400	600	800	1000	Volts
Maximum RMS voltage	$V_{RMS}$	35	70	140	280	420	560	700	Volts
Maximum DC blocking voltage	$V_{DC}$	50	100	200	400	600	800	1000	Volts
Maximum average forward rectified current @ $T_a = 40$	$I_o$	1.5							Amps
Peak forward surge current 8.3ms single half sine-wave superimposed on rated load (JEDEC Method)	$I_{FSM}$	50							Amps
Maximum forward voltage at 1.5A DC	$V_F$	1.1							Volts
Maximum DC reverse current @ $T_j=25$ at rated DC blocking voltage @ $T_j=125$	$I_R$	10 500							$\mu A$
$I^2t$ Rating for Fusing ( $t < 8.3ms$ )	$I^2t$	10.4							$A^2s$
Typical junction capacitance per element (Note 1)	$C_j$	25							PF
Typical thermal resistance (Note 2)	$R_{th-JA}$	40							/ W
Operating temperature range	$T_j$	-55 to +150							
Storage temperature range	$T_{stg}$	-55 to +150							

Note:

1. Measured at 1.0MHz and applied reverse voltage of 4.0V DC

2. Thermal resistance from junction to ambient mounted on P.C.B with 0.5\*0.5" (13\*13mm) copper pads

## Ratings and Characteristic Curves of DB151GS~DB157GS

FIG.1-FORWARD CURRENT DERATING CURVE

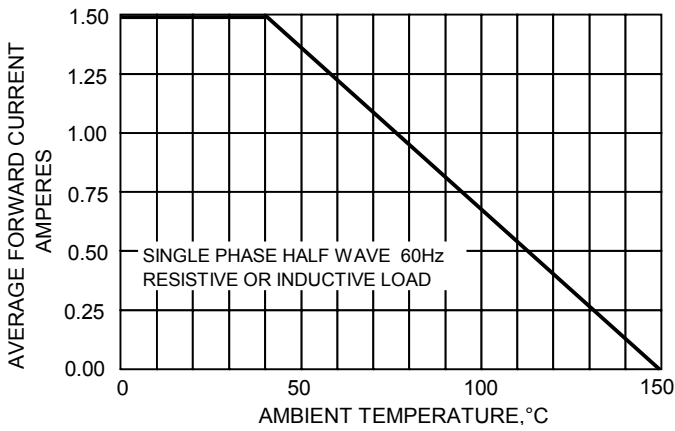

FIG.2-MAXIMUM NON-REPETITIVE SURGE CURRENT

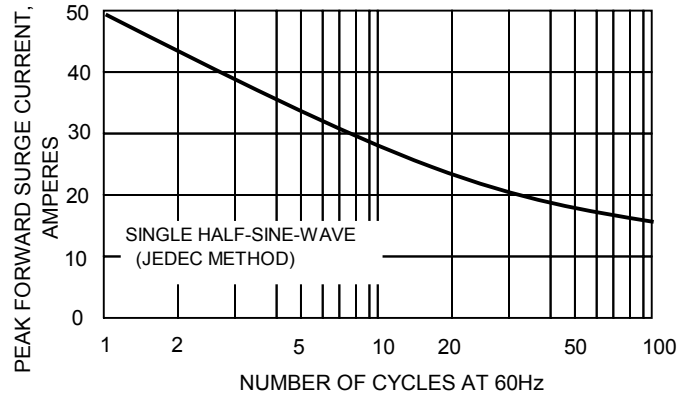

FIG.3-TYPICAL JUNCTION CAPACITANCE

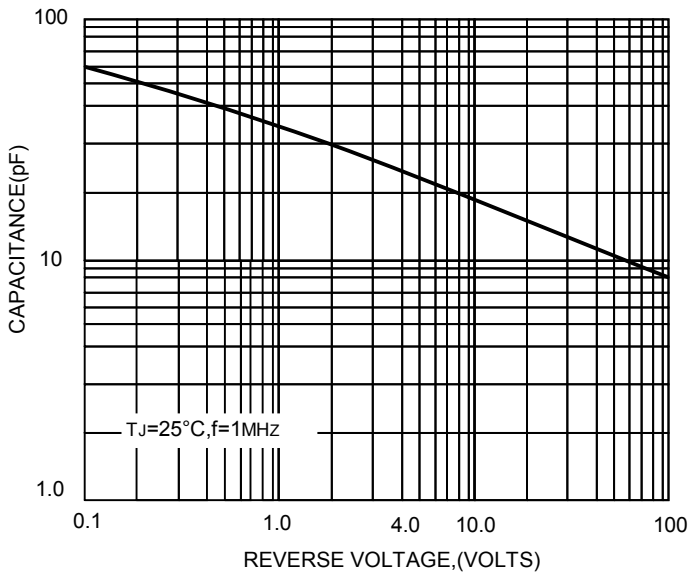

FIG.4-TYPICAL FORWARD CHARACTERISTICS

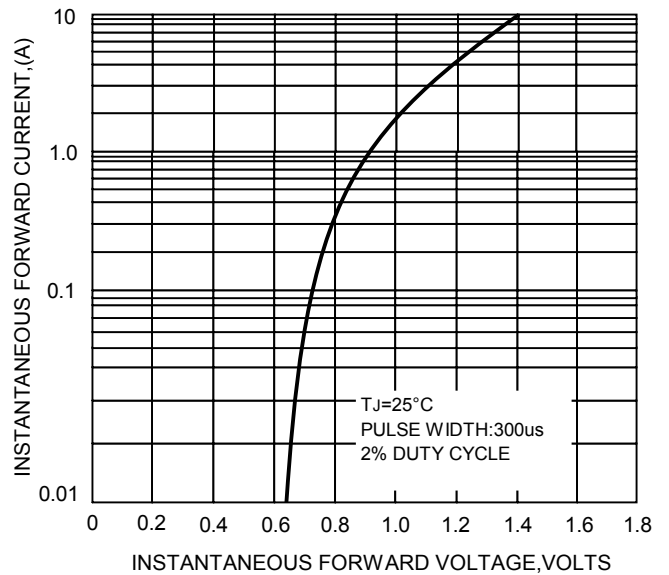

FIG.5-TYPICAL REVERSE CHARACTERISTICS

